

Model 800 SERIES

TELESCOPIC BOOM LIFTS



Performance

Platform Height—Elevated		
800S	80 ft	24.38 m
860SJ	86 ft	26.21 m
Horizontal Outreach		
800S	71 ft	21.64 m
860SJ	75 ft	22.86 m
Capacity on Platform Extension	250 lb	113 kg
Swing	360° Continuous	
Platform Capacity—		
Restricted (800S)	1,000 lb	454 kg
Restricted (860SJ)	750 lb	340 kg
Platform Capacity—		
Unrestricted	500 lb	227 kg
Platform Rotator	180° Hydraulic	
Jib Range of Articulation		
860SJ	130°	+70, -60
Weight ¹		
800S	33,200 lb	15,060 kg
860SJ	36,400 lb	16,511 kg
Max. Ground Bearing Pressure		
800S	72 psi	5.06 kg/cm ²
860SJ	81 psi	5.69 kg/cm ²
Drive Speed 2WD	3.5 mph	5.6 kmph
Drive Speed 4WD	3.5 mph	5.6 kmph
Gradeability 2WD	30%	
Gradeability 4WD	45%	
Turning Radius		
Inside	12 ft	3.66 m
Outside	22 ft 6 in.	6.86 m

1. Certain options or country standards will increase weight.

Standard Specifications

Engine

Dual Fuel Engine, GM Vortec 3000MPFI	82 hp	61 kW
Diesel Engine, Deutz D2011L04 with EGR	64 hp	47 kW
Fuel Tank Capacity	31 gal	117.3 L

Hydraulic Reservoir

• Capacity	40 gal.	151.42 L
• Pump	Fixed Displacement Gear	

Tires

• Standard	15-625 Wide Lug Thread	
• Pump	15-625 Foam-Filled	
	18-625 Foam-Filled	



Standard Features

- Inward Swinging Gate
- Dual-Rated Capacities
- SkyPower® Package
- Hydraulic Platform Rotator
- Swing-Out Engine Tray
- 12V DC Auxiliary Power
- Fuel Gauge
- All Motion Alarm
- Gull-Wing Hoods
- Operators Tool Tray
- Lifting/Tie Down Lugs
- Glow Plugs (Diesel Engines)
- 6 ft (1.83 m) Articulating Jib (860SJ Only)
- Platform: 36 x 96 in. (0.91 x 2.44 m) Side Entry
- Oscillating Axle
- 110V AC Receptacle in the Platform
- 5 Degree Tilt Alarm/Indicator Light
- Hourmeter
- Control ADE® System
- Proportional Controls
- Hydrostatic Drive
- Platform Console Machine Status Light Panel*
- Engine Distress Warning/Shutdown—
Selectable via JLG Analyzer

* Provides indicator lights at platform control console for system distress, fuel level, low fuel, 5 degree tilt light and foot switch status.

Accessories & Options

- Mesh to Top Rail
- Light Package¹
- Soft-Touch System
- Catalytic Muffler
- Hostile Environment Kit³
- Tow Package
- Platform Worklights
- Platform: 36 x 72 in. (0.91 x 1.83 m)
- Fall Arrest Platform (Requires Foam Filled Tires)
- Flashing Amber Beacon
- Cold Weather Start Kit²
- Arctic Package⁴
- Special Hydraulic Oils (Consult Factory)
- Accessory Packages:
 - SkyWelder®
 - Nite Bright®
 - Pipe Rack
 - SkyGlazier®
 - SkyCutter®
 - SkyAir®

1. Includes platform mounted work lights and drive/backup lights.

2. Engine block heater, battery heater and oil tank heater.

3. Includes console cover, boom wipers and cylinder bellows.

4. Includes arctic hydraulic hoses (drive and steer only and main boom cable, arctic hydraulic oil, extreme cold engine oil, anti-freeze)

Model 800 SERIES

TELESCOPIC BOOM LIFTS

Dimensions

All dimensions are approximate.

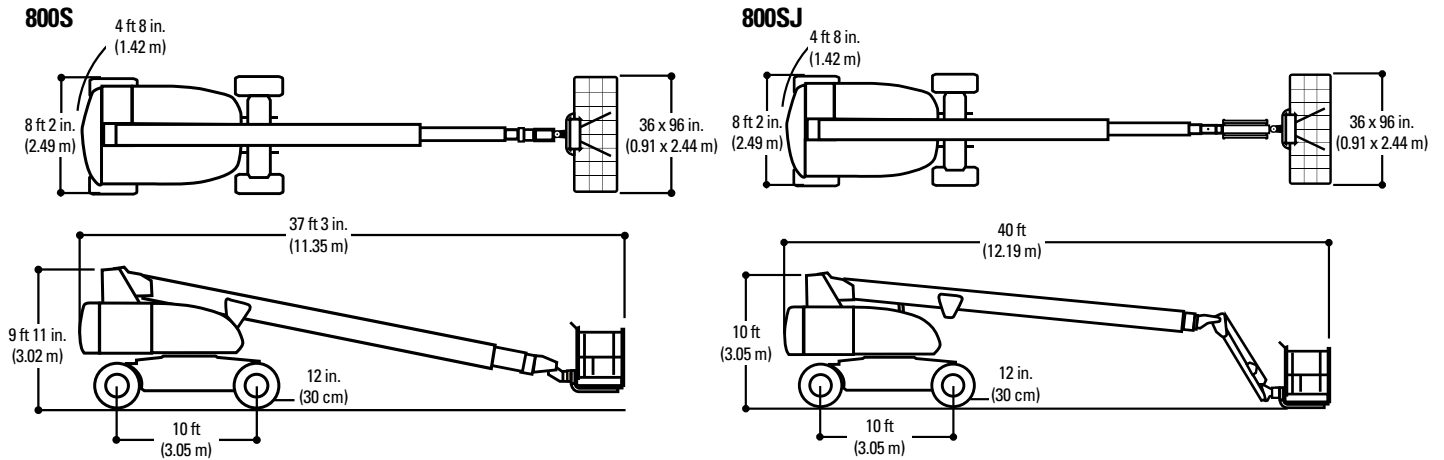

Reach Diagrams

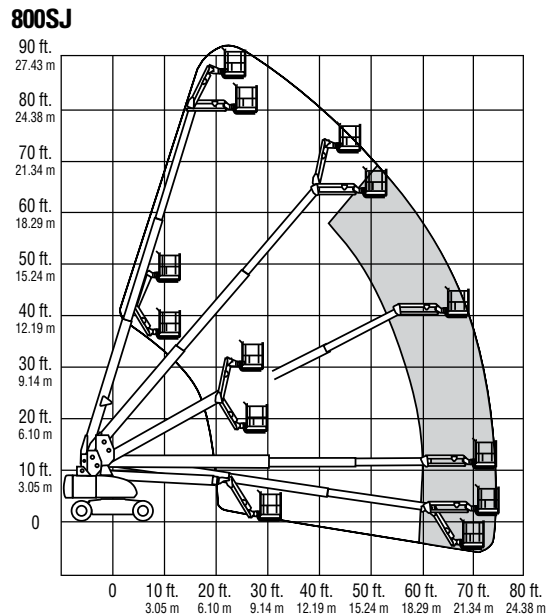
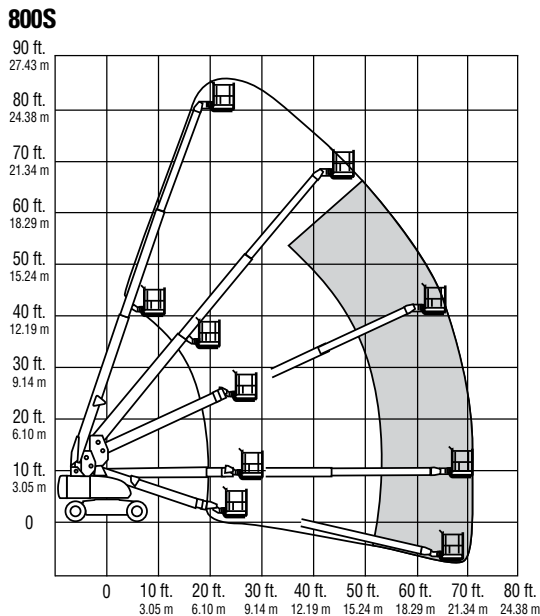

The JLG "1 & 5" Warranty

JLG Industries, Inc. backs its products with its exclusive "1 & 5" Warranty. We provide coverage on all products for one (1) full year, and cover all specified major structural components for five (5) years. Due to continuous product improvements, we reserve the right to make specification and/or equipment changes without prior notification. This machine meets or exceeds applicable OSHA Regulations in 29 CFR 1910.67, 29 CFR 1926.453, ANSI A92.5-2006, and CSA Standard CAN3-B354.2-M82, as originally manufactured for intended applications.

Form No.: SS-800S-0906-15M
 Part No.: 3131024
 R081311
 Printed in USA

JLG Industries, Inc.
 1 JLG Drive
 McConnellsburg, PA 17233-9533
 Telephone 717-485-5161
 Toll-free in US 877-JLG-LIFT
 Fax 717-485-6417
www.jlg.com

An Oshkosh Corporation Company